

Aurelia Installation Requirements

POWER Requirements

Aurelia MDX Grinder(s)



220V; 30A; 1 PHASE
PLUG: NEMA L6-30 TWIST



110V; 15A; 1 PHASE
PLUG: NEMA 5-15

Power must be within 3 feet of machine

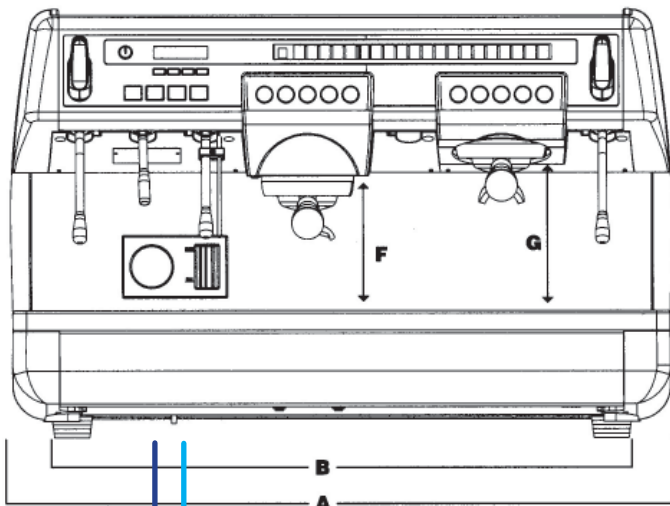

Water Supply and Drain must be within 3 feet of machine

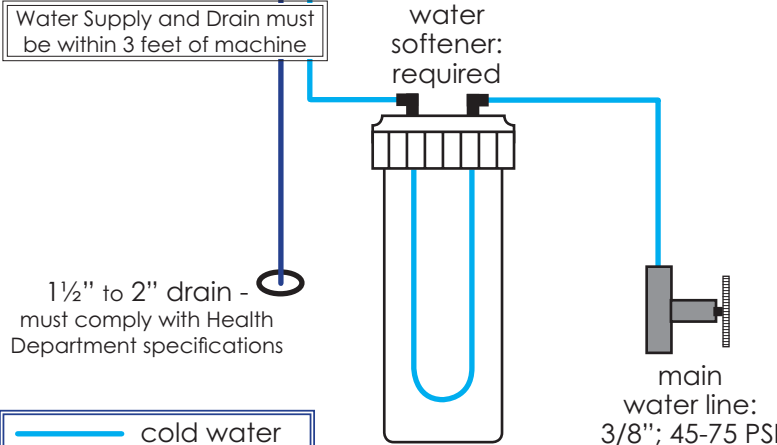

1 1/2" to 2" drain - must comply with Health Department specifications



WATER Requirements:

A dedicated shut-off, 3/8" female valve attached to a softened, "cold" water line, between 3-5 Bar of pressure within three feet of the machine.

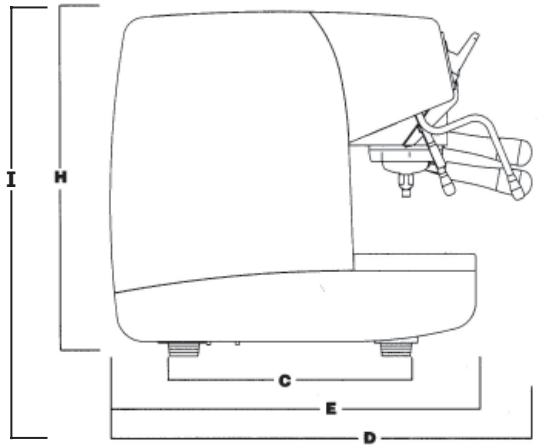
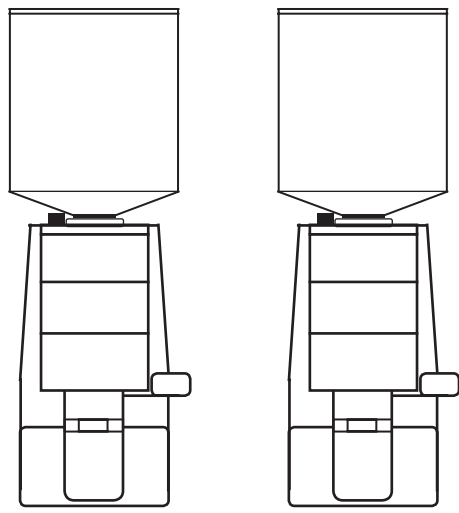

I: Measurement includes 4" extension legs required by some health departments

model	net weight	gross weight	power	boiler capacity	dimensions								
					A	B	C	D	E	F	G	H	I
2 group	176lbs	210lbs	4500W	14lt	31"	27"	15"	25"	22"	5"	7"	21"	25"
3 group	194lbs	225lbs	5000W	20lt	40"	27"	15"	25"	22"	5"	7"	21"	25"
4 group	229lbs	317lbs	5000W	26lt	49"	27"	15"	25"	22"	5"	7"	21"	25"